

Generator set
Sound-proof type
QSV37KS-AU

SPECIFICATIONS

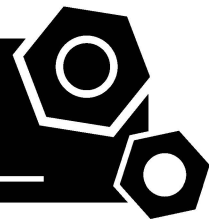

QS series QSV37KS-AU

50 Hz @ 1500rpm,3-phase/5-wiring

1 Standards & Conditions

Design Standards

The designs and the productions are in conformity with:

- Conformite Europeenne (CE)
- ISO8528-5:2005
- GB/T2820.5-2009

Environmental Operating Conditions

- Installation place: Outdoors or indoors (well ventilated).
- Ambient temperature: -25°C to 50°C. The coolant heater is needed when the temperature is below 5°C
- Humidity: Less than 90%.
- Altitude: Below one thousand (1000) meters above sea level.

Factory Inspection

- Inspection items.
- Protection devices working test.
- Starting ability in normal temperature.
- 50% rated power load moment capability.
- Voltage deviation and speed variation: 0%, 25%, 50%, 75%, 100%, 110% Load.

Painting Process

- Painting process specifications and colors are based on the manufacturer's standard.
- The customer could also choose the color which the manufacturer offers.

2 General Features

- Kubota engine V3300-T-E2BG2
- Close coupled to LSA alternator LSA42.3VS5
- Microprocessor control module PLC-920
- SCHNEIDER main circuit breaker: 63A
- Rotate speed governor: Electronic governor
- Excitation system: Self excited,SHUNT
- A.V.R model: R220
- Key switch
- Emergency stop switch
- ATS(automatic transfer switch)receptacle

- Remote run connector
- 1x12V/60AH sealed for life maintenance free battery
- Lockable battery isolator switch
- Powder coated canopy
- 45°C radiator
- Steel base frame
- Vibration isolators between the engine/alternator and base frame
- Dry type air filter
- Base fuel tank for 8 hours running
- Drain points for fuel tank
- Operation Manual / Specifications

3 Equipment

General technical data

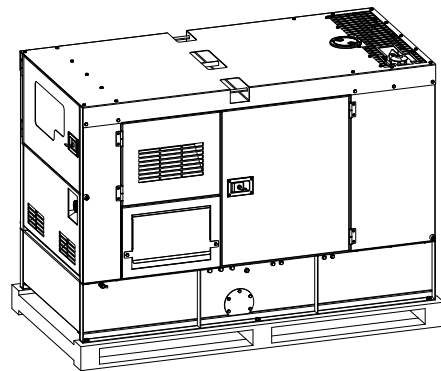

Model.....QSV37KS-AU
 Tank capacity..... 160L
 Dry weight..... 1404kg
 Sound pressure level @ 7m N/A
 Dimensions L×W×H.....2508x1081x1709mm
 Standby Power 41kVA/32kW
 Prime Power 37kVA/30kW

Voltage	380V	400V	415V	440V	
Ampere	57.0A	54.1A	52.5A	49.2A	
Genset Fuel Consumption					
Frequency/Load	25%	50%	75%	100%	110%
50Hz (L/h)	N/A	5.1	7.2	9.0	10.0

Diesel engine

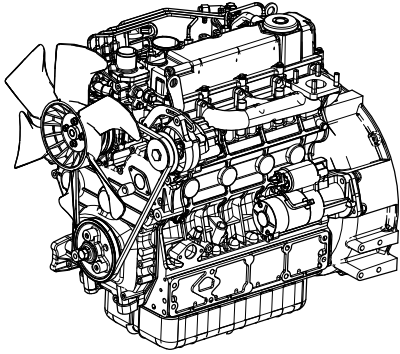

Engine Manufacturer/Brand.....	KUBOTA
Engine Model.....	V3300-T-E2BG2
Dimensions L×W×H.....	769.2×536×803.1mm
Dry Weigh (approx.)	250kg
Number of Cylinders.....	4
Bore.....	98mm
Stroke.....	110mm
Displacement.....	3.318L
Compression Ratio.....	21.8
Type of Injection	Spherical Type (E-TVCS)
Intake System.....	Turbo
Intake Resistance.....	1.96kPa
Cooling System	Water cooled
Fan	Pusher
Battery Voltage	12V
Type of Fuel.....	Diesel Fuel No.2-D(ASTM D975)
Type of Oil	Class CF lubricating oil
Oil Capacity	13.2L
Type of Coolant	Glycol mixture
Coolant Capacity.....	N/A
Back Pressure	≤7.07kPa
Standby Power	35.3kW
Prime Power.....	32.1kW
Fuel Consumption(100%load).....	9.0L/h

Alternator

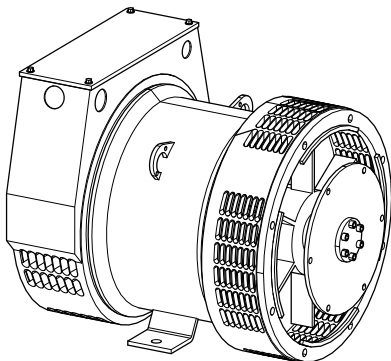

Alternator Manufacturer/Brand	Leroy Somer
Alternator Model	LSA42.3VS5
Exciter.....	Brushless
Cooling Fan	Cast alloy aluminum
Windings.....	100% copper
Insulation Class	H
Winding Pitch.....	2/3
Terminals	12
Drip Proof	IP23
Altitude.....	≤1000m
Overspeed	2250rpm
Air Flow.....	N/A
Voltage Regulation	±0.5%
Total Harmonic TGH / THCat no load < 3 % - on load < 2%	
Telephone Interference.....	THF<2%;TIF<50

PLC-920 Control System

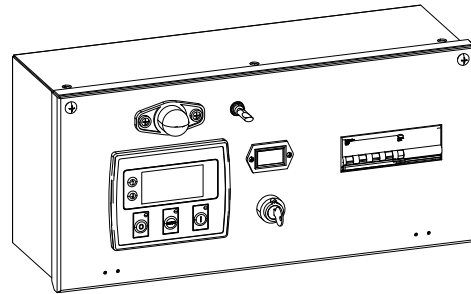

PLC-920 is an advanced control module based on microprocessor designed to control the engine via push buttons on the front panel. The module is used to start and stop the engine and indicate fault conditions, automatically shutting down the engine and giving a true first up fault condition of an engine failure.

Standard Control Function

- Manual Engine Control Module
- Low Oil Pressure
- High Engine Temperature
- Auxiliary Shutdown
- Overspeed Protection
- Protection hold-off timer
- Charge Failure warning

4 Overall Dimensions

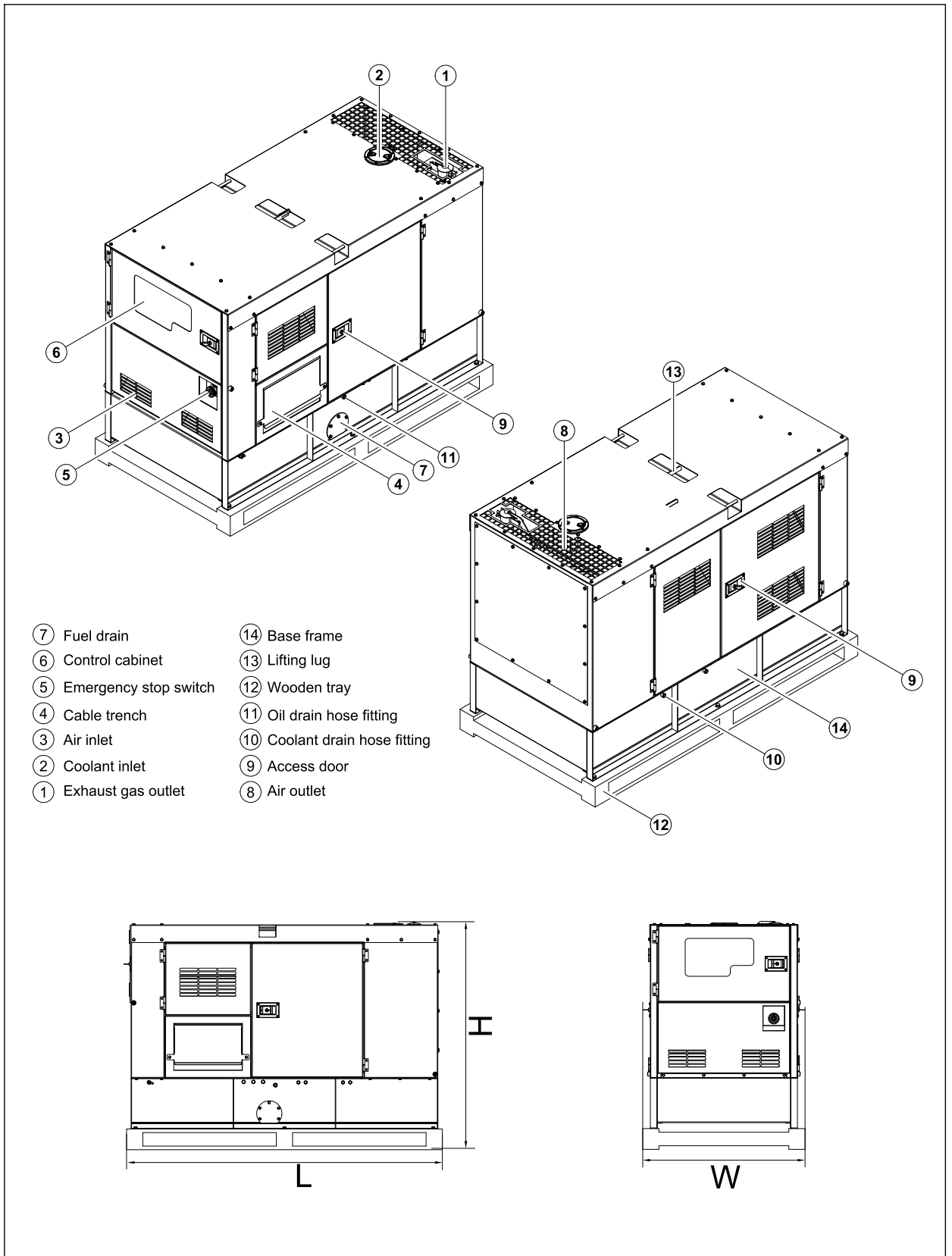

5 Control System

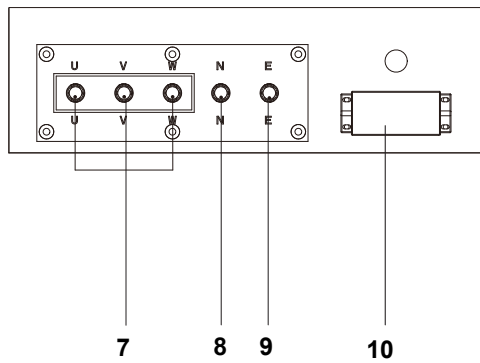
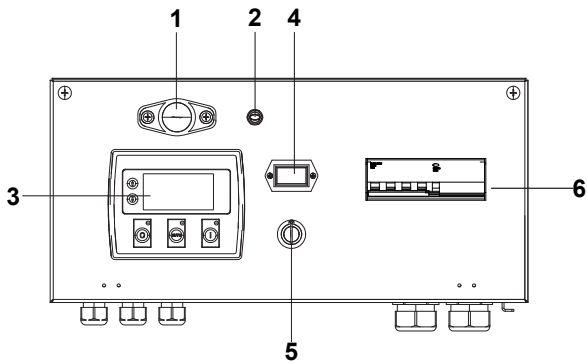

Control & field wiring cabinet

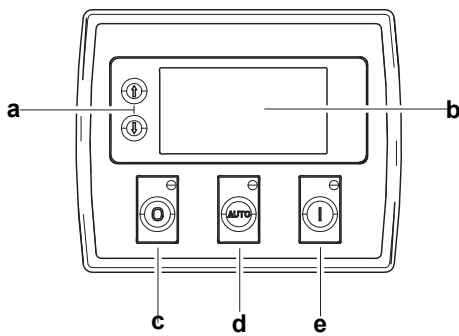

Control module

Ref.	Description
1	Control cabinet lamp
2	Control cabinet lamp switch
3	Control module
4	Time counter
5	Key switch
6	Main circuit breaker
7	Live wire terminals
8	Neutral wire terminal
9	Ground wire terminal
10	Mains input/remote communication connector

Ref.	Description
a	Navigation button«» Accept (Configuration mode only)
b	Main status display
c	Stop/reset button«» Next page (Configuration mode only)
d	Auto start button«» Decrease value/next item (Configuration mode only)
e	Start button«» Increase value/next item (Configuration mode only)