

SPECIFICATION



MODEL QSV150PS **QSV SERIES** **(FOR 50Hz DIESEL GENSET)**

Revision: A2 (10/22)

QSV series

QSV150PS



50 Hz @ 1500rpm, 3-phase/5-wiring

1 Standards & Conditions

Design Standards

The designs and the productions are in conformity with:

- Conformance European (CE)
- ISO8528-5:2005
- GB/T2820.5-2009

Environmental Operating Conditions

- Installation place: Outdoors or indoors (well ventilated).
- Ambient temperature: -25°C to 45°C. The coolant heater is needed when the temperature is below 5°C
- Humidity: Less than 80%.
- Altitude: Below one thousand (1000) meters.

Factory Inspection

- Inspection items.
- Protection devices working test.
- Starting ability in normal temperature.
- 50% rated power load moment capability.
- Voltage deviation and speed variation: 0%, 25%, 50%, 75%, 100%, 110% Load.

Painting Process

- Painting process specifications and colors are based on the manufacturer's standard.
- The customer could also choose the color which the manufacturer offers.

2 General Features

- Perkins engine 1106A-70TAG2
- Close coupled to a LeroySomer alternator LSA44.3L10
- Microprocessor control module PLC-920
- NADER main circuit breaker: 250A
- Rotate speed governor: Mechanical governor
- Excitation system: Self excited shunt
- A.V.R model: R250
- Key switch
- Emergency stop switch
- ATS (automatic transfer switch) receptacle

- 1x12V/120AH sealed for life maintenance free battery
- Lockable battery isolator switch
- Powder coated canopy
- 50°C radiator
- Oil pump on the engine
- Steel base frame with forklifts
- Vibration isolators between the engine/alternator and base frame
- Dry type air filter
- Base fuel tank for 8 hours running
- Drain points for fuel tank
- Operation Manual / Specifications

3 Equipment Specification

General technical data

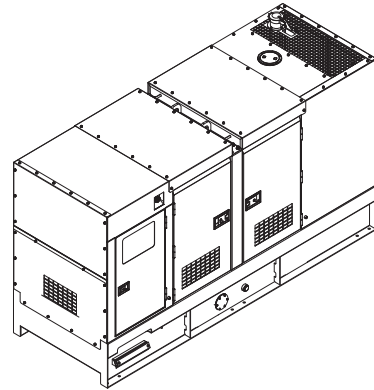

Model.....QSV150PS
 Structure type R
 Tank capacity.....300L
 Dry weigh.....2253kg
 Noise level @7m 64dB(A)
 Dimensions L×W×H..... 3150x1230x1703mm
 Standby Power 165kVA/132kW
 Prime Power 150kVA/120kW

Voltage	380V	400V	415V	440V	
Ampere	227.9A	216.5A	208.7A	196.8A	
Genset Fuel Consumption					
Frequency/Load	25%	50%	75%	100%	110%
50Hz (L/h)	9.1	16.4	24.7	33.4	36.1

Diesel Engine

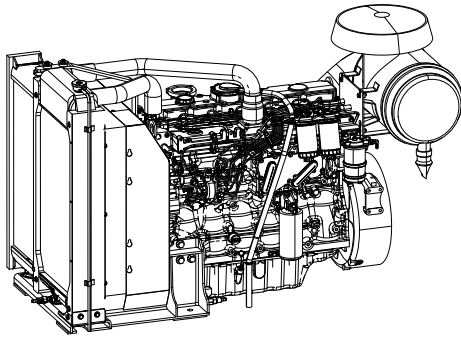

Engine Manufacturer/Brand.....	Perkins
Engine Model.....	1106A-70TAG2
Dimensions L×W×H.....	1706×756×1092mm
Dry Weigh (approx.)	743kg
Number of Cylinders.....	6
Bore.....	105mm
Stroke	135mm
Displacement.....	7.01L
Compression Ratio.....	18.2
Type of Injection	Direct injection diesel
Intake System.....	Turbocharged and air charge cooled
Intake Resistance	≤3.0kPa
Cooling System	Water cooled
Fan	Pusher
Battery Voltage	12V
Type of Fuel.....	EPA2D 89.330-96
Type of Oil	API-CC/SE or CCMC-D1
Oil Capacity	18.0L
Type of Coolant	Glycol mixture
Coolant Capacity	20.5L
Back Pressure	≤6kPa
Standby Power	149.1kW
Prime Power	136.0kW
Fuel Consumption(100%load).....	33.4L/h

Alternator

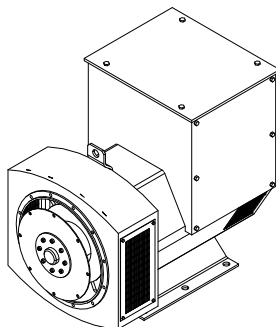

Alternator Manufacturer/Brand	LeroySomer
Alternator Model	LSA44.3L10
Exciter.....	Brushless
Cooling Fan	Cast alloy aluminum
Windings.....	100% copper
Insulation Class	H
Winding Pitch.....	2/3
Terminals	12
Drip Proof	IP23
Altitude.....	≤1000m
Overspeed	2250rpm
Air Flow.....	0.37m³/s(50Hz),0.44m³/s(60Hz)
Voltage Regulation	±0.5%
Total harmonic TGH / THC at no load < 2 % - on load < 2%	
Telephone Interference.....	THF<2%;TIF<50

PLC-920 Control System

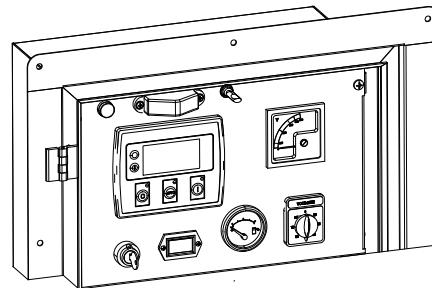

PLC-920 is an advanced control module based on microprocessor designed to control the engine via push buttons on the front panel. The module is used to start and stop the engine and indicate fault conditions, automatically shutting down the engine and giving a true first up fault condition of an engine failure.

Standard Control Function

- Manual Engine Control Module
- Low Oil Pressure
- High Engine Temperature
- Auxiliary Shutdown
- Overspeed Protection
- Protection hold-off timer
- Charge Failure warning

4 Overall Dimensions

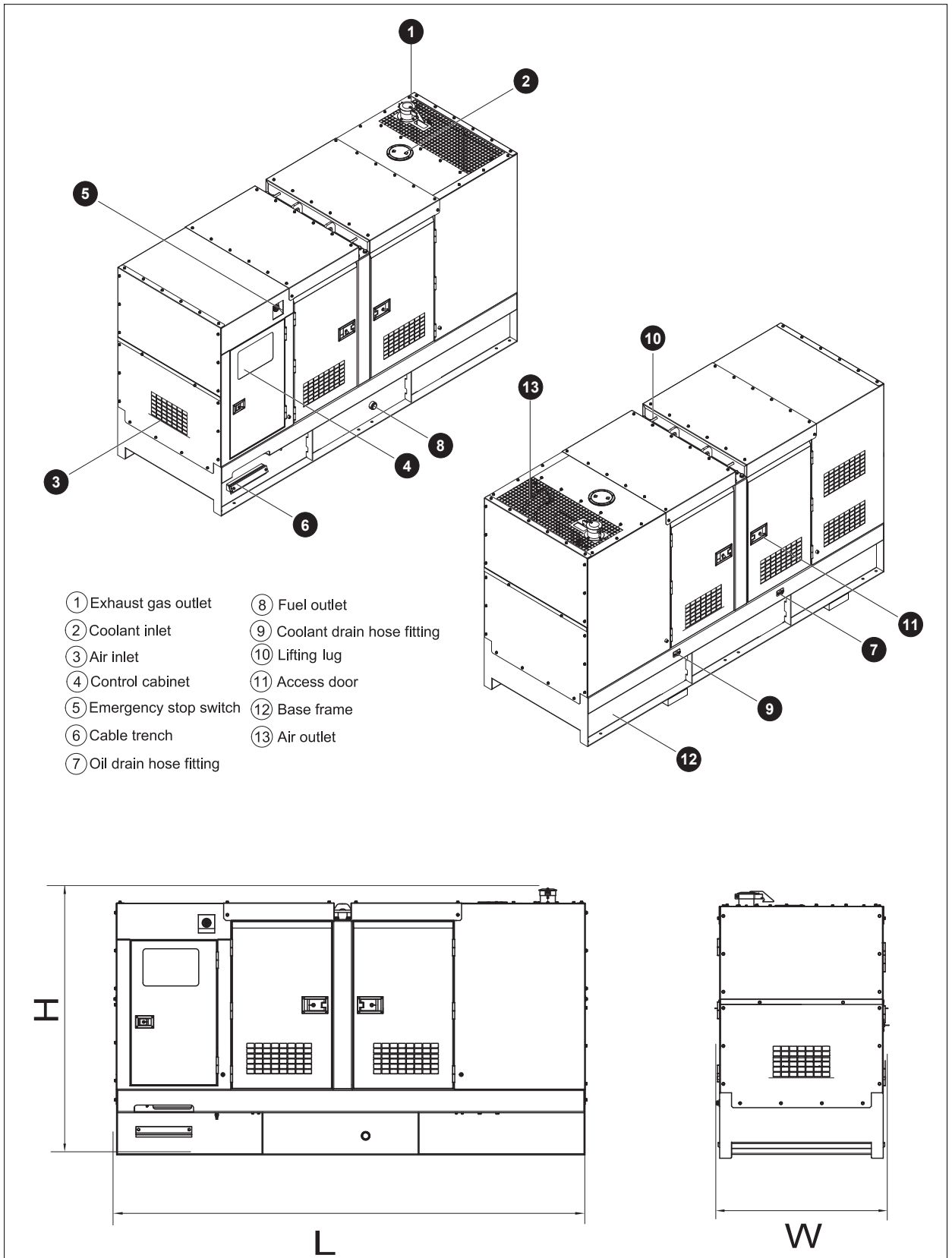

6 Control System

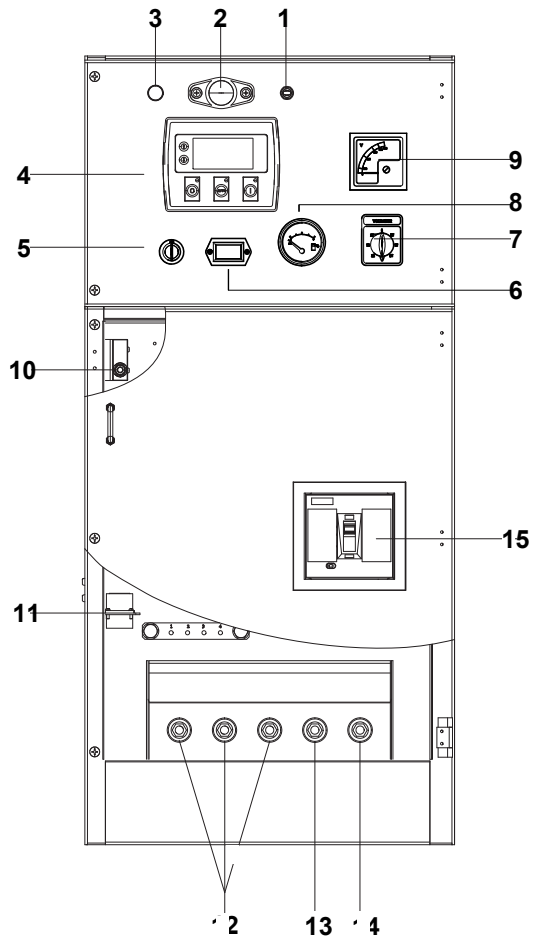

Control & field wiring cabinet

Ref.	Description
1	Control cabinet lamp switch
2	Control cabinet lamp
3	Charge indicator
4	Control module
5	Key switch
6	Time counter
7	Voltage changer-over switch
8	Fuel level meter
9	Voltage meter
10	Limit switch
11	Mains input/Remote control/ATS connector
12	Live wire terminal
13	Neutral wire terminal
14	Ground wire terminal
15	Main circuit breaker

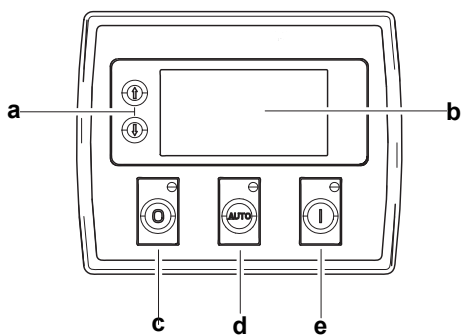

Control module

Ref.	Description
a	Navigation button£» Accept (Configuration mode only)
b	Main status display
c	Stop/reset button£» Next page (Configuration mode only)
d	Auto start button£» Decrease value/next item (Configuration mode only)
e	Start button£» Increase value/next item (Configuration mode only)