

Generator set

Containerized type

GMS1250CS

SPECIFICATIONS

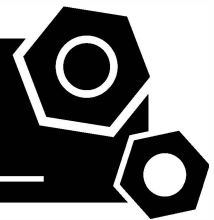

SC series GMS1250CS

50 Hz @ 1500rpm,3-phase/4-wiring

1 Standards & Conditions

Design Standards

The designs and the productions are in conformity with:

- Conformance Européenne (CE)
- ISO8528-5:2005
- GB/T2820.5-2009

Environmental Operating Conditions

- Installation place: Outdoors or indoors (well ventilated).
- Ambient temperature: -25°C to 45°C. The coolant heater is needed when the temperature is below 5°C
- Humidity: Less than 80%.
- Altitude: Below one thousand (1000) meters above sea Level.

Factory Inspection

- Inspection items.
- Protection devices working test.
- Starting ability in normal temperature.
- 50% rated power load moment capability.
- Voltage deviation and speed variation: 0%, 25%, 50%, 75%, 100%, 110% Load.

Painting Process

- Painting process specifications and colors are based on the manufacturer's standard.
- The customer could also choose the color which the manufacturer offers.

2 General Features

- Cummins engine KTA38-G9
- Close coupled to Leroy-somer alternator LSA50.2M6
- Microprocessor control module PLC-7420
- Main circuit breaker: 2000A
- Rotate speed governor: EFC
- Excitation System: AREP
- A.V.R.Model: D350
- Key switch
- Emergency stop switch
- ATS (automatic transfer switch) receptacle
- 2x12V sealed for life maintenance free battery
- Lockable battery isolator switch
- Powder coated canopy

- 50°C radiator
- Fire extinguisher
- Oil pump on the engine
- Steel base frame with forklots
- Vibration isolators between the engine/alternator and base frame
- Dry type air filter
- Fuel tank for 5 hours running
- Drain points for fuel tank
- Fuel inlet pump and it's control box for the fuel tank
- Added fuel-water separator for fuel tank
- Operation Manual / Parts List / Specifications

3 Equipment Specification

General technical data

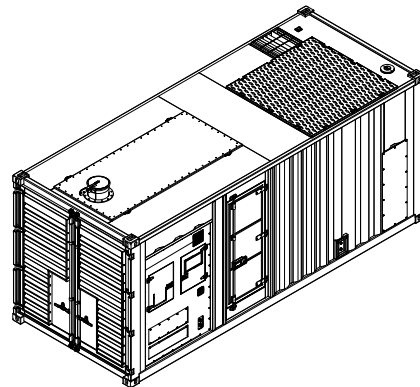

Model.....	GMS1250CS
Structure type	C
Tank capacity.....	1500L
Dry weigh.....	15310kg
Noise level @7m	81.2dBA
Dimensions L×W×H.....	6058×2438×2795mm
Standby Power	1250kVA/1000kW
Prime Power.....	N/A

Voltage	380V	400V	415V		
Ampere	1899A	1804A	1739A		
Genset Fuel Consumption					
Frequency/Load	25%	50%	75%	100%	110%
50Hz (L/h)	76	137	196	256	282

Diesel engine

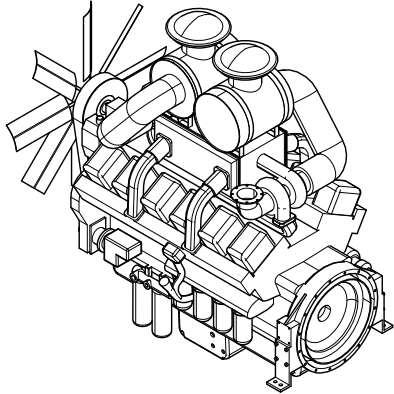

Engine Manufacturer/Brand.....	Cummins
Engine Model.....	KTA38-G9
Dimensions L×W×H.....	N/A
Dry Weigh (approx.)	4366kg
Number of Cylinders.....	12
Bore.....	159mm
Stroke	159mm
Displacement.....	38L
Compression Ratio	14.5
Type of injection.....	Direct injection
Intake System.....	Turbocharged and aftercooled
Intake Resistance	6.23kPa
Cooling System	Water cooled
Fan	Push
Battery Voltage	24V
Type of Fuel.....	NO.2 or ASTMD975
Type of Oil	CF4/SG15W-40
Oil Capacity	135L
Type of Coolant	Glycol mixture
Coolant Capacity (engine only).....	123.8L
Back Pressure	≤10kPa
Standby Power	1089kW
Prime Power	990kW
Fuel Consumption(100%load).....	256L/h

Alternator

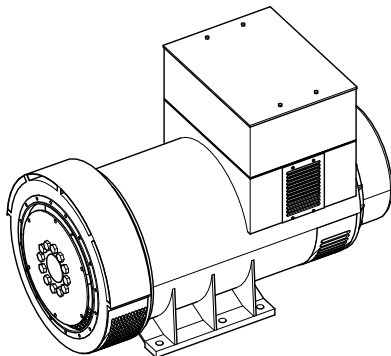

Alternator Manufacturer/Brand	Leroy-somer
Alternator Model	LSA50.2M6
Exciter.....	Brushless
Cooling Fan	Cast alloy aluminum
Windings.....	100% copper
Insulation Class	H
Winding Pitch.....	2/3
Terminals	12
Drip Proof	IP23
Altitude.....	≤1000m
Overspeed	2250rpm
Air Flow.....	2.18m³/s(50Hz),2.63m³/s(60Hz)
Voltage Regulation	±0.5%
Total Harmonic TGH / THCat no load < 1.5 % - on load < 5%	
Telephone Interference.....	THF<2%;TIF<50

PLC-7420 Control System

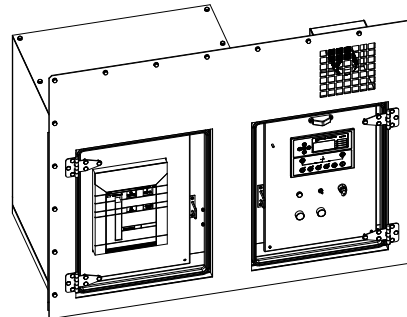

PLC-7420 is an advanced control module based on micro-processor, containing all necessary functions for protection of the genset and the breaker control. It can monitor the mains supply, and automatically start the engine when the mains is abnormal. Accurately measure various operational parameters and display all values and alarms information on the LCD. In addition, the control module can automatically shut down the engine and indicate the engine failure.

- Microprocessor control, with high stability and credibility
- Monitoring and measuring operational parameters of the mains supply and genset
- Indicating operation status, fault conditions, all parameters and alarms
- Multiple protections; multiple parameters display, like pressure, temp. etc.
- Manual, automatic and remote work mode selectable
- Real time clock for time and date display, overall runtime display, 250 log entries
- Overall power output display
- Integral speed/frequency detecting, telling status of start, rated operation, overspeed etc.
- Communication with PC via RS485 OR RS232 interface, using MODBUS protocol

4 Overall Dimensions

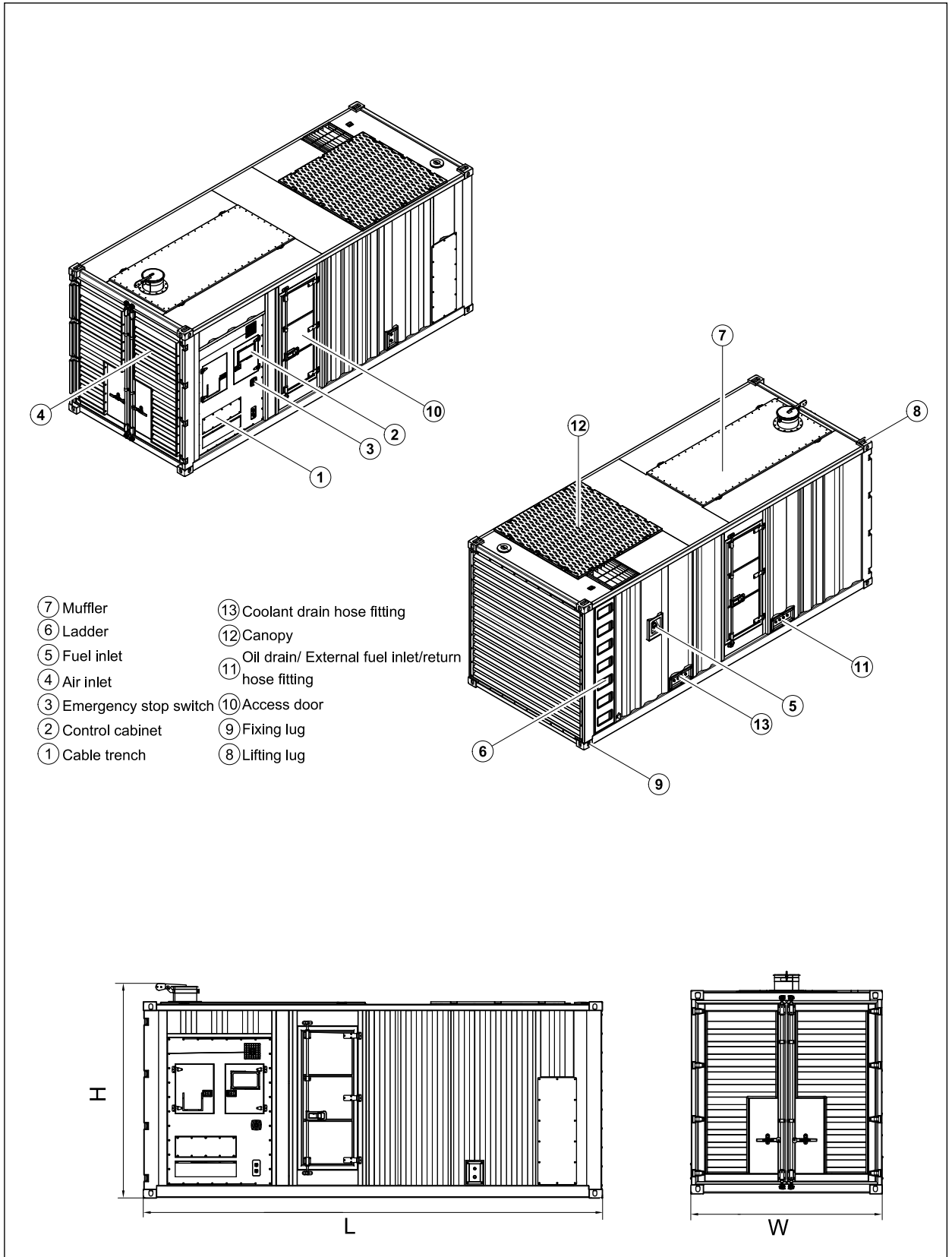

5 Control System

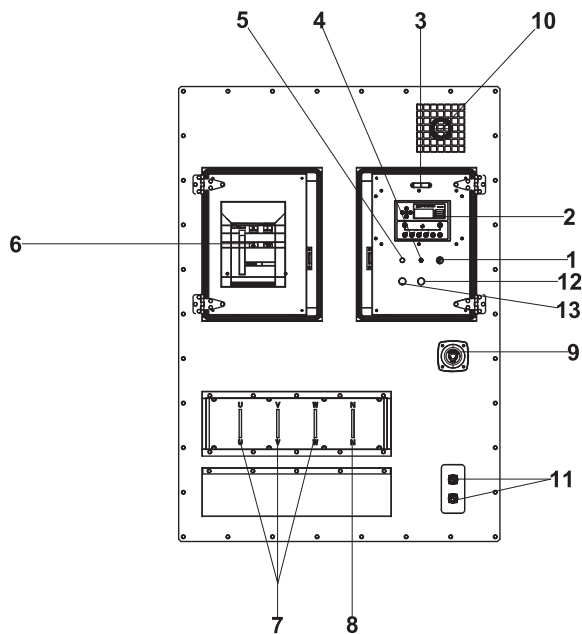

Control & Field wiring cabinet

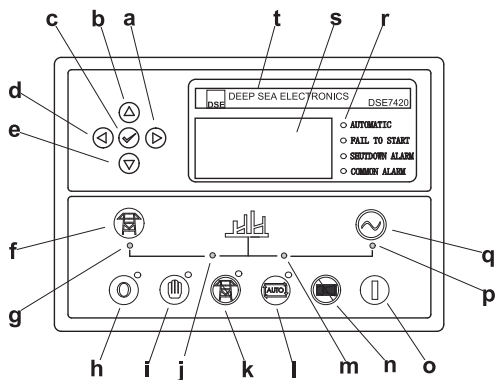

Control Panel

Ref.	Description
1	Key switch
2	Control module
3	Control cabinet lamp
4	Control cabinet lamp switch
5	Charge indicator
6	Main circuit breaker
7	Live wire terminals
8	Neutral wire terminal
9	Emergency stop switch
10	Alarm indicator
11	ATS communication interface
12	Genset circuit breaker OFF button
13	Genset circuit breaker ON button

a	Button (next page)
b	Button (increase value / previous item)
c	Button (accept)
d	Button (previous page)
e	Button (decrease value / next item)
f	Button (transfer the load to the mains supply, when in Manual mode only)
g	Mains supply available LED
h	Stop / Reset button
i	Manual button (Manual control mode)
j	Mains supply on load LED
k	Test button (Test mode)
l	Auto button (Auto mode)
m	Genset on load LED
n	Mute/Lamp test button
o	Start button (Manual)
p	Genset available LED
q	Button (transfer the load to the genset, when in Manual mode only)
r	Alarm LED (4 alarm items)
s	LCD display
t	Control module name