

Generator set
Sound-proof type
GMS10KS

SPECIFICATIONS

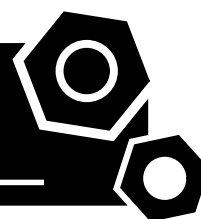

SK series
GMS10KS
 50 Hz @ 1500rpm,3-phase/5-wiring

1 Standards & Conditions

Design Standards

The designs and the productions are in conformity with:

- Conformance European (CE)
- China Compulsory Certification (CCC)
- ISO8528-5:2005
- GB/T2820.5-2009

Environmental Operating Conditions

- Installation place: Outdoors or indoors (well ventilated).
- Ambient temperature: -25°C to 45°C. The coolant heater is needed when the temperature is below 5°C
- Humidity: Less than 80%.
- Altitude: Below one thousand (1000) meters.

Factory Inspection

- Inspection items.
- Protection devices working test.
- Starting ability in normal temperature.
- 50% rated power load moment capability.
- Voltage deviation and speed variation: 0%, 25%, 50%, 75%, 100%, 110% Load.

Painting Process

- Painting process specifications and colors are based on the manufacturer's standard.
- The customer could also choose the color which the manufacturer offers.

2 General Features

- KUBOTA engine D1105-BG
- Close coupled to a Mecc alternator ECP28-2VS/4
- Microprocessor control module PLC-7420
- SCHNEIDER main circuit breaker: 16A
- Rotate speed governor: Mechanical governor
- Excitation system: Self excited, SHUNT
- A.V.R model: DSR
- Key switch
- Emergency stop switch
- ATS (automatic transfer switch) receptacle
- 1x12V/38AH sealed for life maintenance free battery

- Lockable battery isolator switch
- Powder coated canopy
- 50°C radiator
- Oil pump on the engine
- Steel base frame with forklifts
- Vibration isolators between the engine/alternator and base frame
- Dry type air filter
- Base fuel tank for 32 hours running
- Drain points for fuel tank
- Operation Manual / Specifications

3 Equipment Specification

General technical data

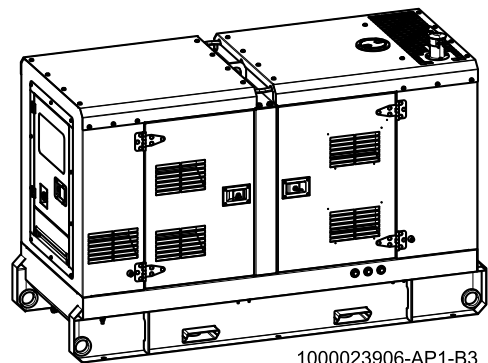

Model.....	GMS10KS
Structure type	RS
Tank capacity.....	100L
Dry weigh.....	615kg
Sound pressure level @ 1m/7m	72.24dB(A)/60.7dB(A)
Sound power acc. 2000/14/EC.....	88.6dB(A)
Dimensions L×W×H.....	1890x790x1257mm
Standby Power	11kVA/9kW
Prime Power	10kVA/8kW

Voltage	380V	400V	415V	440V	
Ampere	15.2A	14.4A	13.9A	13.1A	
Genset Fuel Consumption					
Frequency/Load	25%	50%	75%	100%	110%
50Hz (L/h)	N/A	1.6	2.2	2.9	3.5

Diesel engine

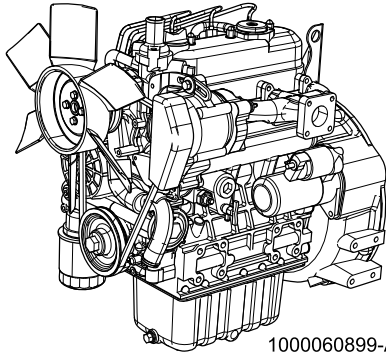

1000060899-AP1-A5

Engine Manufacturer/Brand.....	KUBOTA
Engine Model.....	D1105-BG
Dimensions L×W×H.....	549.3×398.0×604.7mm
Dry Weigh (approx.)	93kg
Number of Cylinders.....	3
Bore.....	78mm
Stroke.....	78.4mm
Displacement.....	1.123L
Compression Ratio.....	22
Type of injection.....	N/A
Intake System.....	Natural aspirated
Intake Resistance.....	1.96kPa
Cooling System.....	Water cooled
Fan.....	Pusher
Battery Voltage.....	12V
Type of Fuel.....	No.2-D(ASTM D975)
Type of Oil.....	Better than API CD class
Oil Capacity.....	5.1L
Type of Coolant.....	Glycol mixture
Coolant Capacity.....	6.4L
Back Pressure.....	≤7.07kPa
Standby Power.....	9.5kW
Prime Power.....	8.4kW
Fuel Consumption(100%load).....	220g/kW.h

Alternator

1000184522-AP1-B3

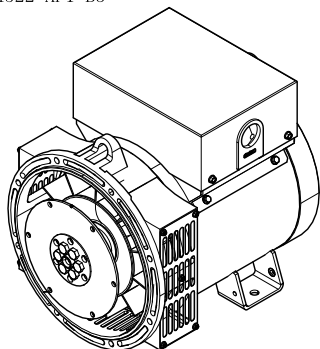

Alternator Manufacturer/Brand.....	Mecc alte
Alternator Model.....	ECP28-2VS/4
Exciter.....	Brushless
Cooling Fan.....	Cast alloy aluminum
Windings.....	100% copper
Insulation Class.....	H
Winding Pitch.....	2/3
Terminals.....	12
Drip Proof.....	IP23
Altitude.....	≤1000m
Overspeed.....	2250rpm
Air Flow.....	5.3m³/min(50Hz),5.8m³/min(60Hz)
Voltage Regulation.....	±1.0%
Total harmonic TGH / THCat no load < 1.5 % - on load < 5%	
Telephone Interference.....	THF<2%;TIF<45

PLC-7420 Control System

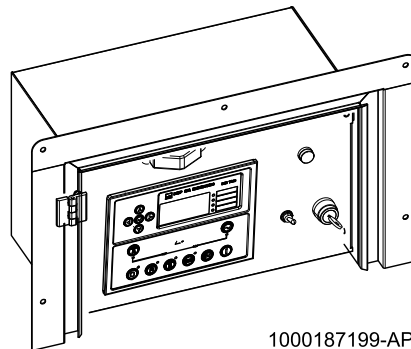

1000187199-AP1-A1

PLC-7420 is an advanced control module based on micro-processor, containing all necessary functions for protection of the genset and the breaker control. It can monitor the mains supply, and automatically start the engine when the mains is abnormal. Accurately measure various operational parameters and display all values and alarms information on the LCD. In addition, the control module can automatically shut down the engine and indicate the engine failure.

- Microprocessor control, with high stability and credibility
- Monitoring and measuring operational parameters of the mains supply and genset
- Indicating operation status, fault conditions, all parameters and alarms
- Multiple protections; multiple parameters display, like pressure, temp. etc.
- Manual, automatic and remote work mode selectable
- Real time clock for time and date display, overall runtime display, 250 log entries
- Overall power output display
- Integral speed/frequency detecting, telling status of start, rated operation, overspeed etc.
- Communication with PC via RS485 OR RS232 interface, using MODBUS protocol

4 Overall Dimensions

1000023906-DR1-B3

Dry weight	615kg
Fuel tank capacity	100L
Dimensions L x W x H	1890x790x1257mm

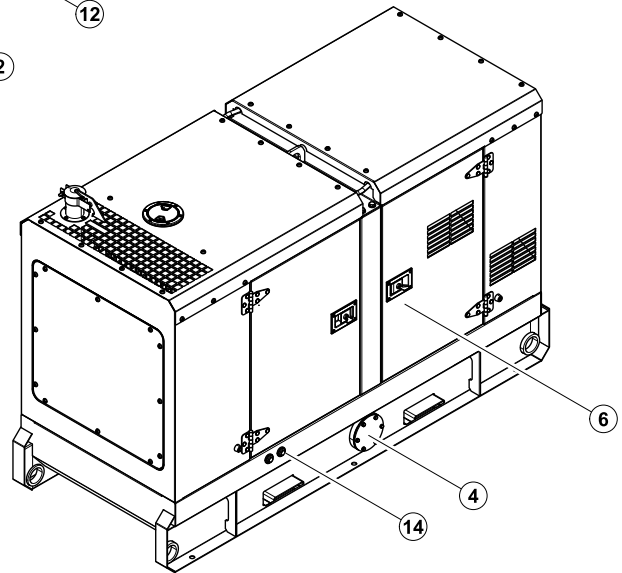
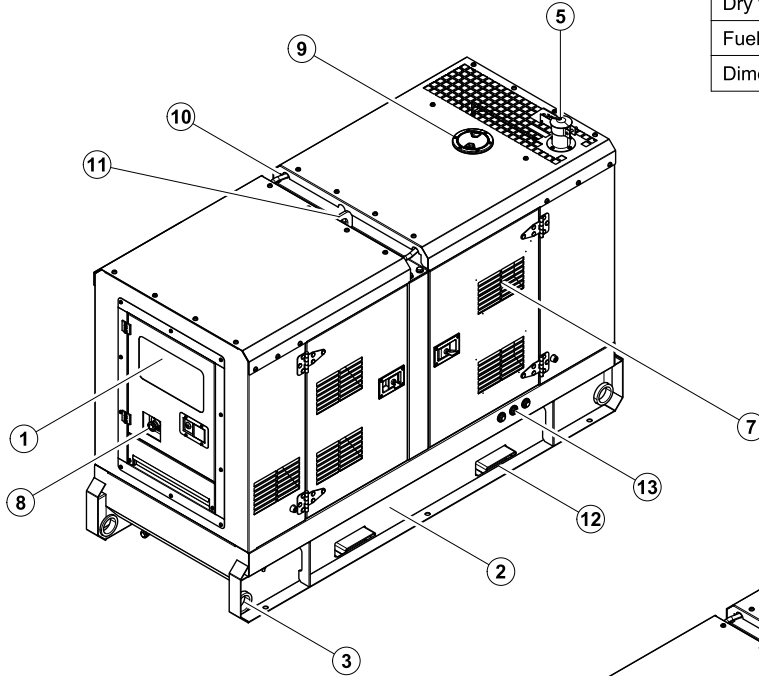

- ⑦ Air inlet
- ⑥ Access door
- ⑤ Exhaust gas outlet
- ④ Fuel drain
- ③ Tie down
- ② Base frame
- ① Control cabinet
- ⑭ Oil drain hose fitting
- ⑬ Coolant / External fuel inlet/return drain
- ⑫ Fork lift channel
- ⑪ Lifting lug
- ⑩ Roping lug
- ⑨ Coolant inlet
- ⑧ Emergency stop switch

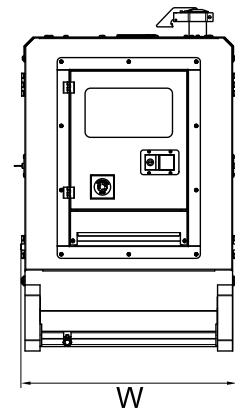
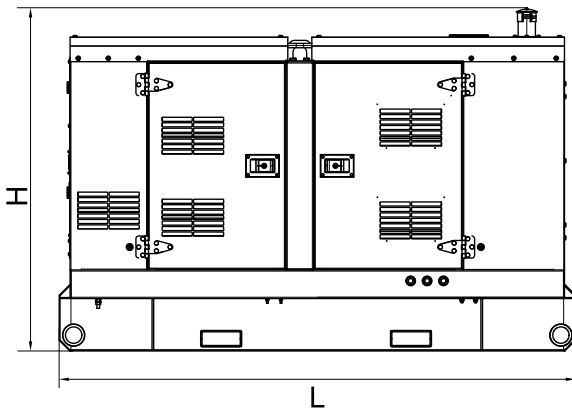

5 Control System

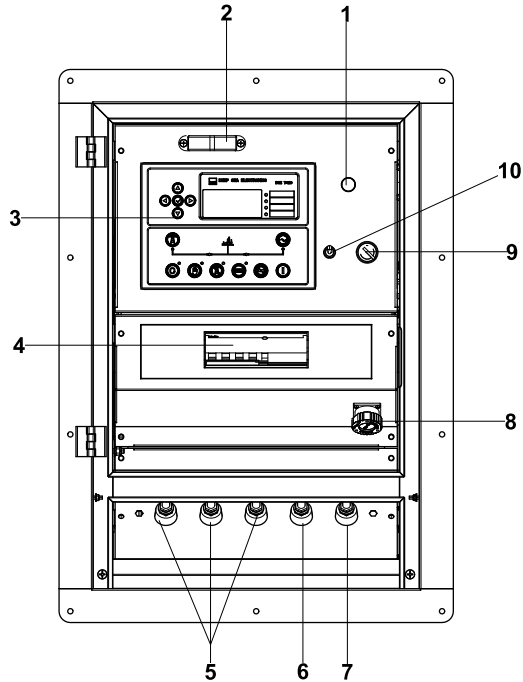

Control & field wiring cabinet

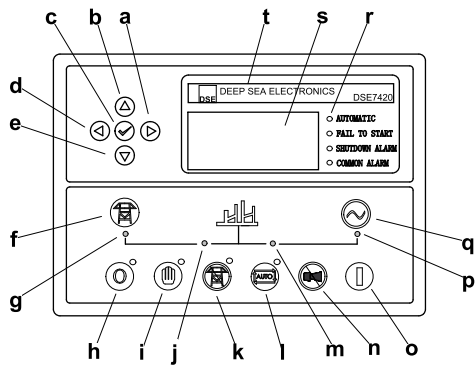

Control module

Ref.	Description
1	Charge indicator
2	Control cabinet lamp
3	Control module
4	Main circuit breaker
5	Live wire terminals
6	Neutral wire terminal
7	Ground wire terminal
8	Mains input/remote/AMF communication connector
9	Key switch
10	Control cabinet lamp switch

a	Button (next page)
b	Button (increase value / previous item)
c	Button (accept)
d	Button (previous page)
e	Button (decrease value / next item)
f	Button (transfer the load to the mains supply, when in Manual mode only)
g	Mains supply available LED
h	Stop / Reset button
i	Manual button (Manual control mode)
j	Mains supply on load LED
k	Test button (Test mode)
l	Auto button (Auto mode)
m	Genset on load LED
n	Mute/Lamp test button
o	Start button (Manual)
p	Genset available LED
q	Button (transfer the load to the genset, when in Manual mode only)
r	Alarm LED (4 alarm items)
s	LCD display
t	Control module name