

Generator set

Sound-proof type

GMS6.6KS

SPECIFICATIONS

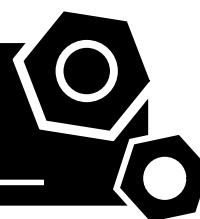

SK series
GMS6.6KS
 50 Hz @ 1500rpm,3-phase/5-wiring

1 Standards & Conditions

Design Standards

The designs and the productions are in conformity with:

- Conformance Europeenne (CE)
- China Compulsory Certification (CCC)
- ISO8528-5:2005
- GB/T2820.5-2009

Environmental Operating Conditions

- Installation place: Outdoors or indoors (well ventilated).
- Ambient temperature: -25°C to 45°C. The coolant heater is needed when the temperature is below 5°C
- Humidity: Less than 80%.
- Altitude: Below one thousand (1000) meters.

Factory Inspection

- Inspection items.
- Protection devices working test.
- Starting ability in normal temperature.
- 50% rated power load moment capability.
- Voltage deviation and speed variation: 0%, 25%, 50%, 75%, 100%, 110% Load.

Painting Process

- Painting process specifications and colors are based on the manufacturer's standard.
- The customer could also choose the color which the manufacturer offers.

2 General Features

- Kubota engine D905-BG
- Close coupled to a Stamford alternator PI044D
- Microprocessor control module PLC-920
- SCHNEIDER main circuit breaker: 16A
- Rotate speed governor: Mechanical governor
- Excitation System: Self excited
- A.V.R.Model: AS480
- Key switch
- Emergency stop switch
- ATS (automatic transfer switch) receptacle
- 1x12V/70AH sealed for life maintenance free battery

- Lockable battery isolator switch
- Powder coated canopy
- 50°C radiator
- Oil pump on the engine
- Steel base frame with forklifts
- Vibration isolators between the engine/alternator and base frame
- Dry type air filter
- Base fuel tank for 50 hours running
- Drain points for fuel tank
- Operation Manual / Specifications

3 Equipment Specification

General technical data

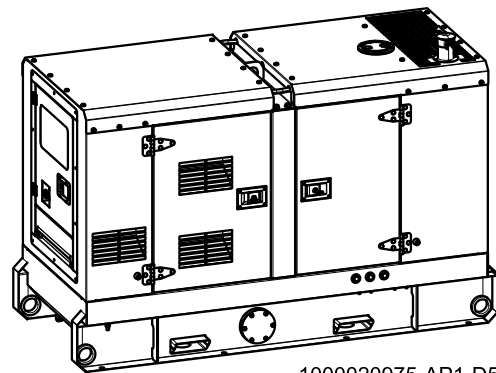

Model.....GMS6.6KS
 Structure typeRS
 Tank capacity.....80L
 Dry weigh.....572kg
 Noise level @7mN/A
 Dimensions L×W×H..... 1790x760x1207mm
 Standby Power 7kVA/6kW
 Prime Power..... 6.6kVA/5.3kW

Voltage	380V	400V	415V	440V	
Ampere	10.0A	9.53A	9.18A	8.66A	
Genset Fuel Consumption					
Frequency/Load	25%	50%	75%	100%	110%
50Hz (L/h)	N/A	0.9	1.3	1.6	1.8

Engine

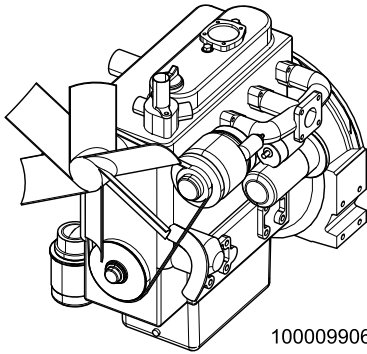

1000099068-AP1-A3

Engine Manufacturer/Brand.....	KUBOTA
Engine Model.....	D905-BG
Dimensions L×W×H.....	551×395×605mm
Dry Weigh (approx.)	93Kg
Number of Cylinders.....	3
Bore.....	72mm
Stroke.....	73.6mm
Displacement.....	0.898L
Compression Ratio.....	23
Type of injection.....	Direct injection
Intake System.....	Natural aspirated
Intake Resistance.....	≤1.96kPa
Cooling System	Water cooled
Fan	Pusher
Battery Voltage	12V
Type of Fuel.....	No.2-D (ASTMD975)
Type of Oil	APICD
Oil Capacity	5.1L
Type of Coolant	Glycol mixture
Coolant Capacity.....	N/A
Back Pressure	≤7.07kPa
Standby Power	7.4kW
Prime Power.....	6.6kW
Fuel Consumption(100%load).....	1.6L/h

Alternator

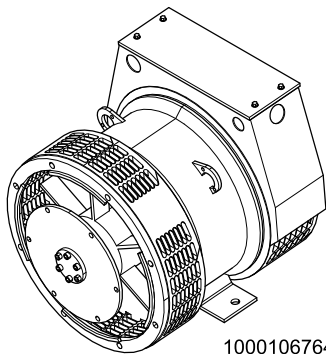

1000106764-AP1-A1

Alternator Manufacturer/Brand	Stamford
Alternator Model	PI044D
Exciter.....	Brushless
Cooling Fan	Cast alloy aluminum
Windings.....	100% copper
Insulation Class	H
Winding Pitch.....	2/3
Terminals	12
Drip Proof	IP23
Altitude.....	≤1000m
Overspeed	2250rpm
Air Flow.....	0.11 m³/s(50Hz),0.135 m³/s(60Hz)
Voltage Regulation	± 1.0 %
Total harmonic TGH / THCat no load < 1.5 % - on load < 5%	
Telephone Interference.....	THF<2%;TIF<50

PLC-920 Control System

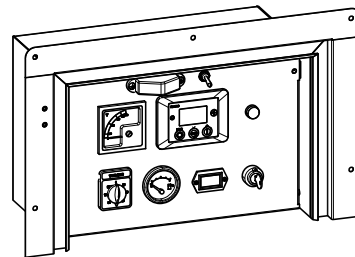

1000094365-AP1-D5

PLC-920 is an advanced control module based on micro-processor designed to control the engine via a key switch and push buttons on the front panel. The module is used to start and stop the engine and indicate fault conditions, automatically shutting down the engine and giving a true first up fault condition of an engine failure.

Standard Control Function

- Manual Engine Control Module
- Low Oil Pressure
- High Engine Temperature
- Auxiliary Shutdown
- Overspeed Protection
- Protection hold-off timer
- Charge Failure warning

4 Overall Dimensions

1000020975-DR1-D5

Dry weight	572kg
Fuel tank capacity	80L
Dimensions L x W x H	1790x760x1207mm

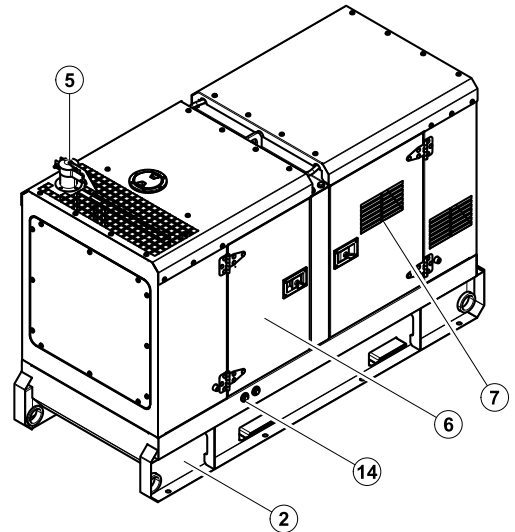
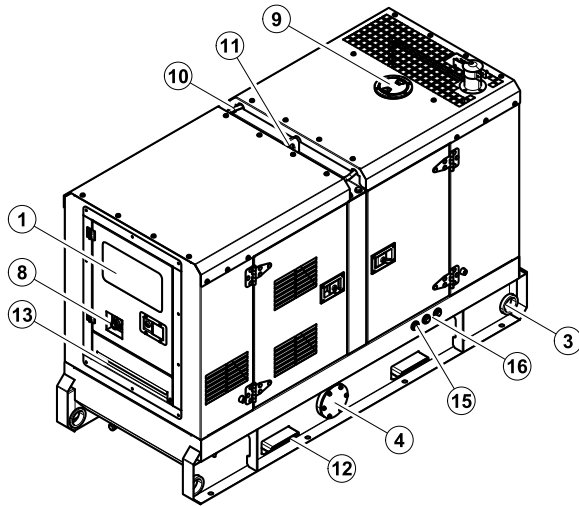

- | | |
|-------------------------|---|
| ⑧ Emergency stop switch | ⑬ Coolant drain hose fitting |
| ⑦ Air inlet | ⑭ External fuel inlet/return hose fitting |
| ⑥ Access door | ⑮ Oil drain hose fitting |
| ⑤ Exhaust gas outlet | ⑯ Cable trench |
| ④ Fuel drain | ⑰ Fork lift channel |
| ③ Tie down | ⑱ Lifting lug |
| ② Base frame | ⑲ Roping lug |
| ① Control cabinet | ⑳ Coolant inlet |

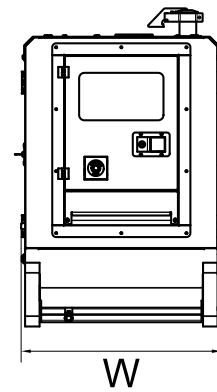
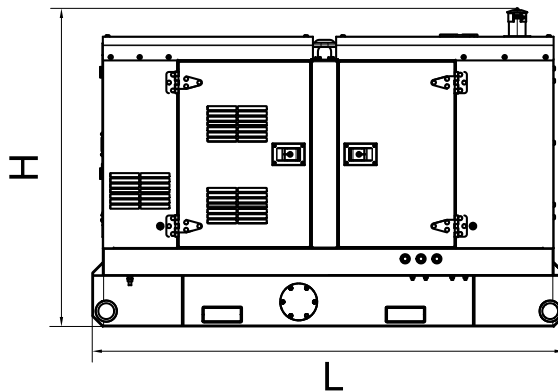

5 Control System

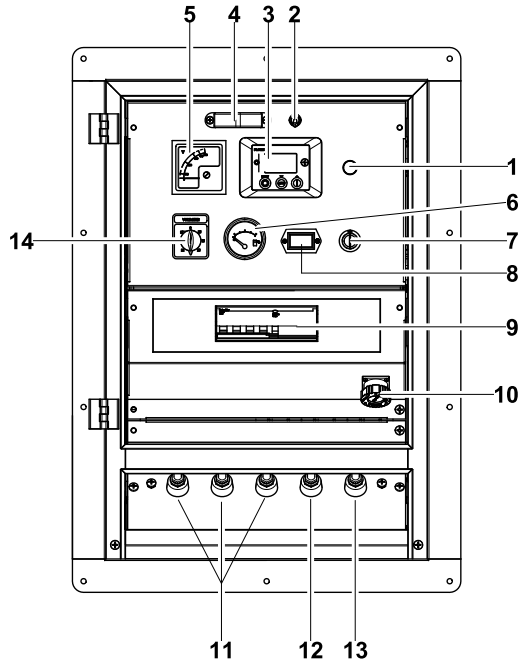

Control & field wiring cabinet

Ref.	Description
1	Charge indicator
2	Control cabinet lamp switch
3	Control module
4	Control cabinet lamp
5	Voltage meter
6	Fuel level meter
7	Key switch
8	Time counter
9	Main circuit breaker
10	Mains input /ATS /Remote communication connector
11	Live wire terminal
12	Neutral wire terminal
13	Ground wire terminal
14	Voltmeter change-over switch

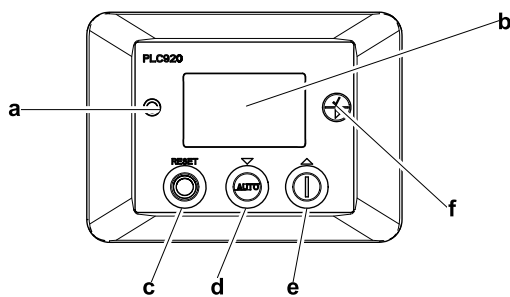

Control module

Ref.	Description
a	Alarm indicator
b	Main status display
c	Stop/reset button; Next page (Configuration mode only)
d	Auto start button; Decrease value/next item (Configuration mode only)
e	Start button; Increase value/next item (Configuration mode only)
f	Navigation button; Accept (Configuration mode only)